

Hydronix

Digital Microwave Moisture Sensor for
Bins, Silos and Conveyors

Hydro-Probe II



THE ORIGINAL – THE LEADER – THE BEST

Hydro-Probe II

Digital microwave moisture sensor for bins, silos and conveyors

The Hydro-Probe II is a rugged, microwave moisture measurement sensor designed to be installed in bins, silos and conveyors in process control environments.

Measuring at 25 times per second and with on-board functionality such as signal processing and averaging, the Hydro-Probe II accurately measures the moisture content of material as it flows over the ceramic faceplate. Remote configuration, calibration, diagnostics and firmware upgrades are simple using Hydronix Hydro-Com software. The linear output allows direct integration with any control system using industry standard interfaces.



Features

- Digital technology provides precise linear moisture measurement.
- The Averaging Mode provides a continuous “average” moisture over a batch.
- Averaging, “Bin Empty” and “High Moisture” Alarms and Signal Processing are performed internally by the sensor.
- The sensor is designed to suit the flow characteristics of the material.
- Link up to 16 sensors using an RS485 connection.
- Fully temperature compensated measurement.
- Fast response to changing conditions with 25 measurements per second.
- Remote communication with Hydro-Com software allows configuration of all sensor parameters including selection of sensor outputs, graphic traces of outputs, calibration of sensor readings and firmware upgrades.
- Consistent performance with no need for recalibration except for use with different materials.
- Tough and reliable with a proven track record.

Angle of Sensor

Ensures continuous flow over the sensor

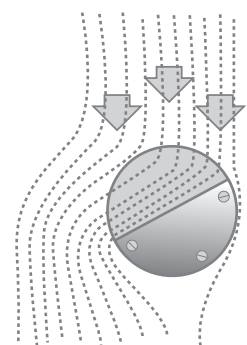

Typical Installation

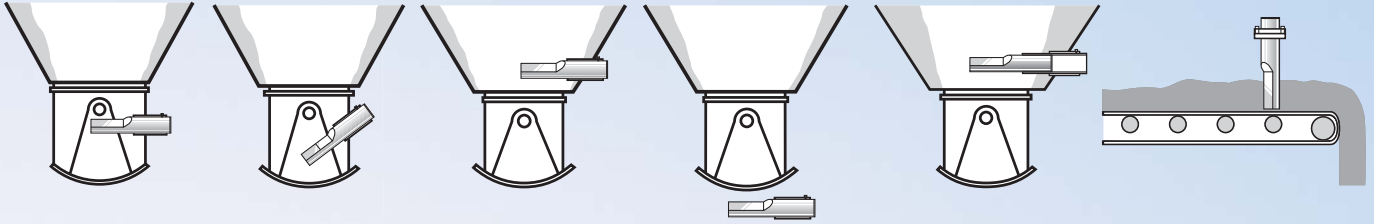

The Hydro-Probe II offers a choice of installation options to suit all bin types and conveyor applications. This ensures that the sensor measures the most representative sample of material.

Connectivity

Digital Connection

Up to 16 Hydro-Probe sensors may be daisy chained to connect directly to a control system via the RS485 serial communications link.



Direct Connection to Control System or PC

The analogue or RS485 serial interface integrates easily with a control system or PC.



Hydro-View Connection

The Hydro-Probe can be connected to a Hydro-View to provide a continuous moisture display. It also enables the sensor to be easily calibrated if calibration facilities are not available on a PC or control system.



Networking

Network up to 16 sensors using one standard Ethernet connection with the Ethernet Adapter Kit. Power over Ethernet option also available.



USB Interface

Easily communicate with the sensor using a USB Sensor Interface Module for sensor diagnostics, configuration and firmware upgrades.



Technical Information

Construction

Body: Stainless Steel

Faceplate: Ceramic

Fixing

The sensor must be placed in the flow of material.

Bins and Silos: Install in the neck of a bin or underneath the gate. Standard and Extension Mounting Sleeves are available to suit different bin widths.

Conveyors: Secure in the flow of material.

Moisture Range

The sensor will measure up to saturation of material.

Penetration of Field

Approximately 75-100mm dependant upon material.

Refresh Rate

25 times per second

Operating Temperature

0-60° C. The sensor will not measure ice.

Analogue Outputs

Configurable 0-20mA or 4-20mA current loop source. For 0-10V DC, 0-20mA should be selected and an external 500R load resistor connected across the analogue input terminals at the control system.

Digital (Serial) Communication

Opto-Isolated RS485 2-wire port. RS232, Ethernet and USB interfaces available.

Communication protocol to access sensor values and parameters over an RS485 network is available on request.

Discrete Inputs

The batch average, start, stop or moisture / temperature multiplexing functions can be controlled via the digital inputs.

Extension Cable

Up to six twisted pairs, 22AWG, 0.35mm² conductors. Screen braid with 65% minimum coverage plus aluminium/polyester foil. Maximum cable run of 100m.

Power Supply

+15V to +30V DC, 4W

Configurable Alarms

The sensor can be set to signal "Bin Empty" or "Moisture Too High" levels.

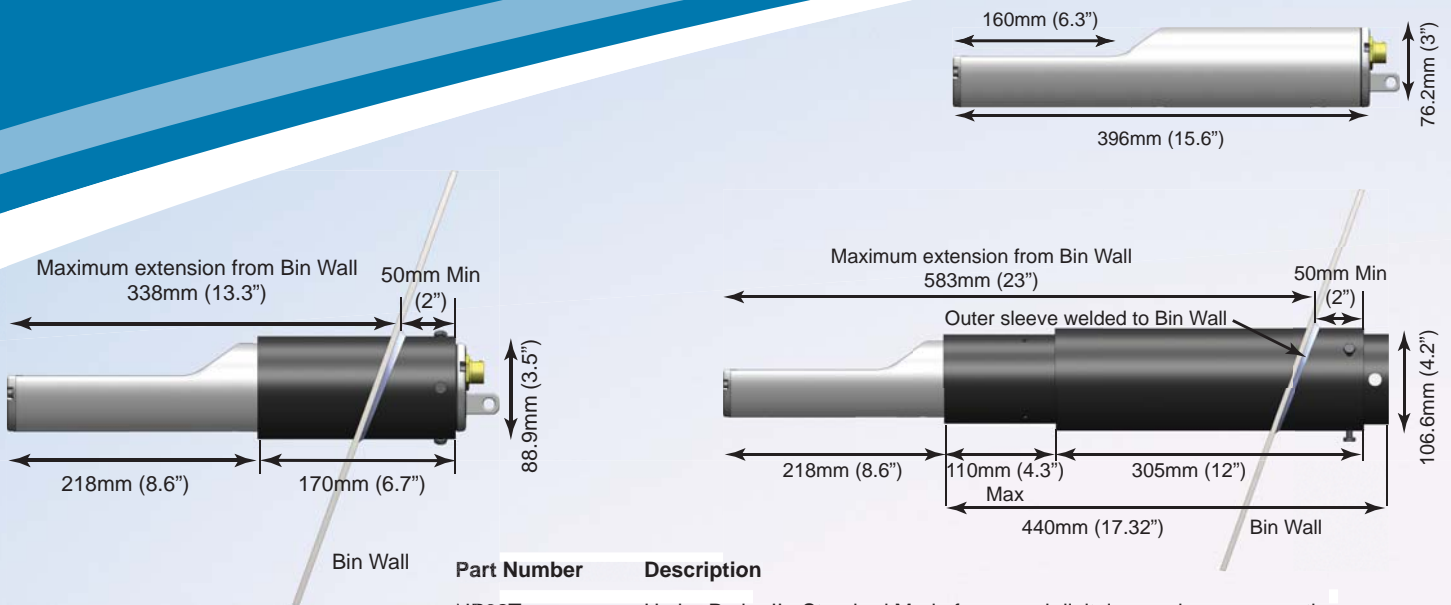

Part Number	Description
HP02T	Hydro-Probe II - Standard Mode for normal digital or analogue connection
HP02C	Hydro-Probe II - Compatible with the Hydro-View Interface Unit
0025	Standard Mounting Sleeve
0026	Extension Mounting Sleeve
0975	4m Sensor Cable with military specification sensor connector
0069	4m Compatibility Cable, 4 core with Bulgin Connector
0067	Terminal Box (IP66, 10 Terminals)
0116	24VDC Power Supply 30 watt for up to 4 Sensors
0049A	RS232-485 Adapter DIN rail mounting
0049B	RS232-RS485 Converter, 9 pin D-type to Terminal Block
SIM01-A	USB Sensor Interface Module including cables and power supply
EAK01	Ethernet Adapter Kit
EPK01	Ethernet Power Kit
P2EW	4 Year extended warranty option



Hydronix